

DE-BUG magnetic diesel filter is the Patented and proven cure of diesel bug, including microbial contamination. DE-BUG is a one time fit and forget solution and once installed in the fuel line, the DE-BUG treatment unit cleans and polishes your diesel fuel as your appliance is operating.

DeBug L500

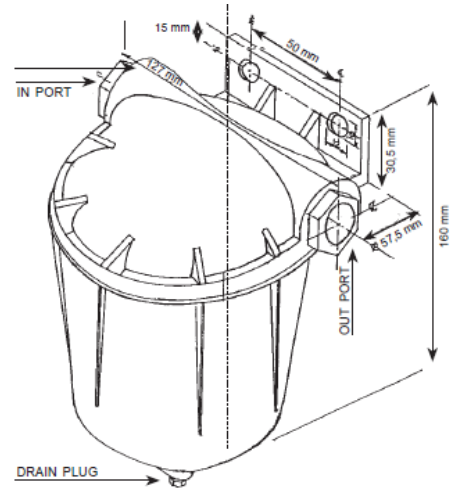

FUEL TYPES	Diesel fuel, marine diesel, light oils and gas oil
RECOMMENDED FLOW RATE	Up to 500 litres/hour
FLOW DIRECTION WITH UNIT MOUNTED	Left to right
MATERIALS	Marine grade LM6 anti-corrosive aluminium alloy.
WEIGHT	1.5 Kg
SIZE	115mm diameter by 150 mm high by 124 mm wide.
PORT SIZE	½ inch NPT
OPERATING PRESSURE	50 psi
INSTALLATION	Two 10mm bolts.

